

DESCRIPTION:	250ml Mountain Water Bottle		ITEM CODE:	MOUNTAIN250	
COLOUR:	Flint / Green		WEIGHT:	180g	
NOMINAL CAPACITY:	250ml	BRIMFULL CAPACITY:	265 ± 6.0ml	CLOSURE:	28mm MCA3
PASTEURISATION:	Yes	CARBONATION:	3.5 Bar	THERMAL SHOCK:	Yes ± 17.7°C
HEIGHT:	200.6 ± 1.5mm	DIAMETER:	55.9 ± 1.2mm	FILL HEIGHT:	48mm
BODY LABEL PANEL:	72.1mm	NECK LABEL PANEL:	mm	VACUITY:	16.6ml 6.6%
PALLET HEIGHT:	1.382m	PALLET WEIGHT:	478kg	UNITS PER PALLET:	2460 – 6 Layers
DRAWING CHECKED:	J.Harrison	DATE CHECKED:	14-Jun-16	DRAWING REF:	1529-C-15

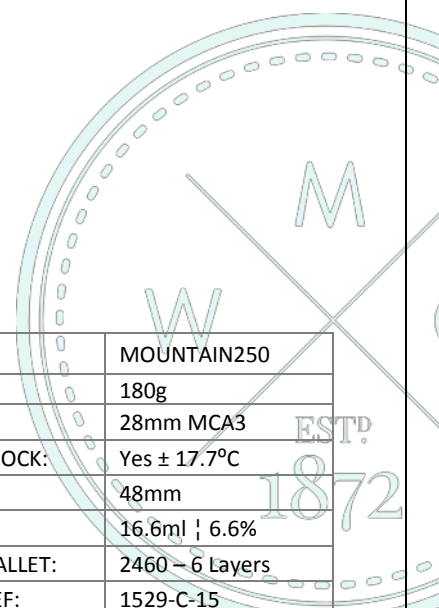

All measurements are approximate unless tolerances stated then are in accordance with ISO9058:2008, E&OE excepted.
 Clients should run trials and check physical samples prior to any full scale production. - - -